

| LOC | DIST | REVISIONS |         |              |         |     |      |
|-----|------|-----------|---------|--------------|---------|-----|------|
| J   |      | P         | LTR     | DESCRIPTION  | DATE    | DWN | APVD |
|     |      | C         | REVISED | FJB0-0063-05 | 25JAN05 | J.Z | I.E  |

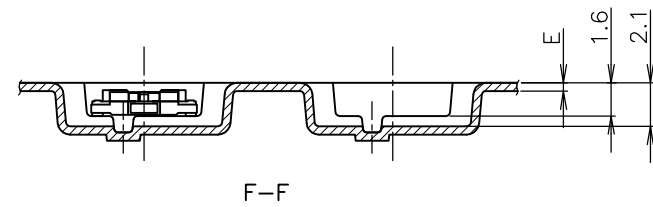

TOP OF REEL

WEEDING THE COVER TAPE AROUND THE OUTER PERIPHERY IN A TURN.  
 165°~180° PEELING ANGLE.

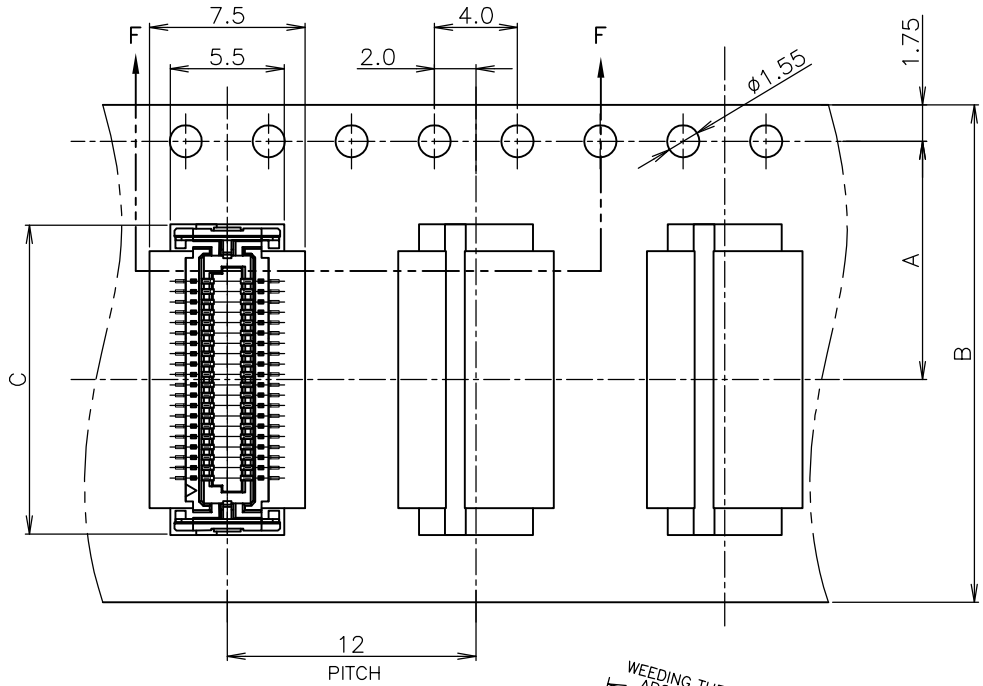
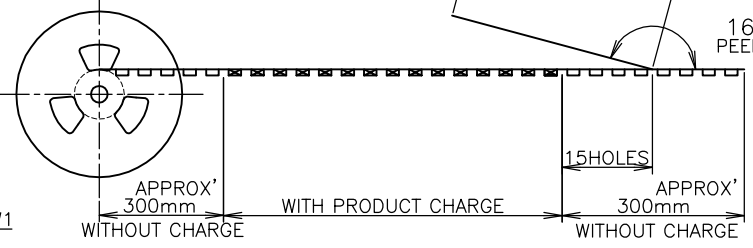
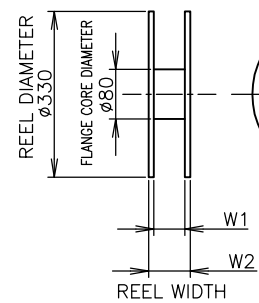

| 28.4           | 24.4           | 0.4 | 15.0 | 24 | 11.5 | 1500     | 40  | 4-353686-0          | 4-353687-0 |
|----------------|----------------|-----|------|----|------|----------|-----|---------------------|------------|
| 28.4           | 24.4           | 0.4 | 12.5 | 24 | 11.5 | 1500     | 30  | 3-353686-0          | 3-353687-0 |
| 28.4           | 24.4           | 0.4 | 10.0 | 24 | 11.5 | 1500     | 20  | 2-353686-0          | 2-353687-0 |
| W <sub>2</sub> | W <sub>1</sub> | E   | C    | B  | A    | QTY/REEL | POS | CONNECTOR P/N (L/P) | TAPING P/N |

INSTRUCTION SHEET  
411-5781

|  |  |                               |  |  |
|--|--|-------------------------------|--|--|
| THIS DRAWING IS A CONTROLLED DOCUMENT. |  | DWN<br>S.KAJINUMA<br>05DEC96  | Tyco Electronics AMP K.K.<br>Kawasaki, Japan   |  |
| DIMENSIONS: MM                         |  | CHK<br>K.ASAKAWA<br>05DEC96   | ON TAPING (EMBOSS)<br>0.5mm PITCH FS CONN. RECEPTACLE ASSEMBLY<br>WITH KEY & WITHOUT BOSS & POLYIMIDE FILM |  |
| TOLERANCES UNLESS OTHERWISE SPECIFIED: |  | APVD<br>S.KUBOUCHI<br>05DEC96 | DRAWING NO<br>C=353687   |  |
| 0 PLC ± 0.2                            |  | RESTRICTED TO                 |  |  |
| 1 PLC ± 0.2                            |  | SIZE A3                       |  |  |
| 2 PLC ± 0.2                            |  | CAGE CODE 00779               |  |  |
| 3 PLC ± 0.2                            |  | SCALE 4:1                     |  |  |
| 4 PLC ± 0.2                            |  | SHEET 1 OF 1                  |  |  |
| ANGLES ± 3'                            |  | REV C                         |  |  |
| MATERIAL FINISH                        |  | CUSTOMER DRAWING              |  |  |